



自贡硬质合金有限责任公司
成都格润特新材料有限公司
ZIGONG CEMENTED CARBIDE CORP., LTD.
CHENGDU GERUNTE HIGH-TECH MATERIAL CO., LTD.



螺纹刀具 Taps



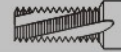

● 切削丝锥 Machine taps

直径范围 Diameter mm	公差等级 Tolerance class	总长 Length mm	供货标准 Technical of the delivery conditions
M3 ~ M20	4H/6H/6G	≤150	ISO/DIN/ANSI/JSA/BSI/GB
被加工材料 To-be machined material	钢、不锈钢、高温合金、钛合金、铸铁、铝合金 Steels, Stainless steels, Heat-resistant steels, Titanium alloys, Cast iron, Aluminium alloys		

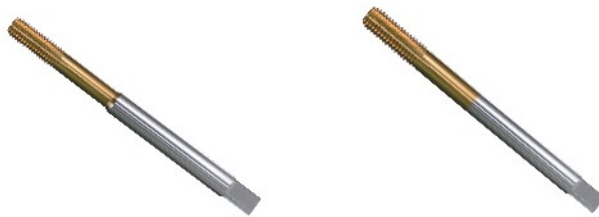

● 挤压丝锥 Ground thread taps

直径范围 Diameter mm	公差等级 Tolerance class	总长 Length mm	供货标准 Technical of the delivery conditions
M4 ~ M20	4H/6H/6G	≤150	ISO/DIN/ANSI/JSA/BSI/GB
被加工材料 To-be machined material	铝合金 Aluminium alloys		



● 螺纹铣刀 Thread mills

直径范围 Diameter mm	公差等级 Tolerance class	总长 Length mm	供货标准 Technical of the delivery conditions
M4 ~ M20	4H/6H/6G	≤150	ISO/DIN/ANSI/JSA/BSI/GB
被加工材料 To-be machined material	钢、不锈钢、高温合金、钛合金、铸铁、铝合金 Steels, Stainless steels, Heat-resistant steels, Titanium alloys, Cast iron, Aluminium alloys		



自贡硬质合金有限责任公司
成都格润特新材料有限公司
ZIGONG CEMENTED CARBIDE CORP., LTD.
CHENGDU GERUNTE HIGH-TECH MATERIAL CO., LTD.



铣削刀具 Mills cutter



铣削刀具 Mills cutter



- 立铣刀 End mills
- 球头铣刀 Ball nose mills

直径范围 Diameter mm	刃数 Flutes	直径公差等级 Dia tolerance class	总长 Length mm	供货标准 Technical of the delivery conditions
Ø3 ~ Ø30	2/3/4/6	$\begin{matrix} h9/e8 \\ \Delta_{\min}=0.01 \end{matrix}$	≤ 200	DIN6529-92
被加工材料 To-be machined material	钢、不锈钢、高温合金、钛合金、铸铁、铝合金 Steels, Stainless steels, Heat-resistant steels, Titanium alloys, Cast iron, Aluminium alloys			



- 锥度铣刀 Taper end mills

直径范围 Diameter mm	刃数 Flutes	直径公差等级 Dia tolerance class	总长 Length mm	供货标准 Technical of the delivery conditions
Ø12 ~ Ø30	2/4/6	$\Delta_{\min}=0.01$	≤ 150	DIN6529-92 ZGST*
被加工材料 To-be machined material	不锈钢、耐高温钢 Stainless steels-resistant steels,			



- 模具铣刀 Die milling cutter

直径范围 Diameter mm	刃数 Flutes	直径公差等级 Dia tolerance class	总长 Length mm	供货标准 Technical of the delivery conditions
Ø3 ~ Ø20	2/4/6	$\Delta_{\min}=0.01$	≤ 150	DIN6529-92
被加工材料 To-be machined material	钢、模具钢 Steels, Die steels			



- 高速铣刀 HSC mills

直径范围 Diameter mm	刃数 Flutes	直径公差等级 Dia tolerance class	总长 Length mm	供货标准 Technical of the delivery conditions
Ø3 ~ Ø20	2/3/4/6	$\Delta_{\min}=0.01$	≤ 150	DIN6529-92 ZGST*
被加工材料 To-be machined material	钢、高温合金、钛合金、铝合金 Steels, Heat-resistant steels, Titanium alloys, Aluminium alloys			
Properties	Revolution: 8000~20000rev/min			



自贡硬质合金有限责任公司
成都格润特高新材料有限公司
ZIGONG CEMENTED CARBIDE CORP., LTD.
CHENGDU GERUNTE HIGH-TECH MATERIAL CO., LTD.



拉削刀具 Broachers









刀具硬质合金牌号及性能

Cemented carbide physical and mechanical properties

ZGST 牌号 Grade	平均粒度 Average grain size	密度 Density	抗弯强度 TRS	洛氏硬度 Hardness	ISO应用分组 ISO
	(μm)	(g/cm^3)	(N/mm^2)	HRA	
K10-1	0.65	14.8	3000	93.0	K10
k10-2	0.45	14.8	3600	93.5	
k30-1	0.50	14.5	4300	92.5	K20/k30
k30-2	0.70	14.6	3200	92.2	
k30-3	0.65	14.9	3600	91.5	
k30-4	0.45	14.5	4000	91.5	
k40-1	0.65	14.5	3600	91.7	k40

刀具涂层牌号及性能

Coating grade and characteristics

涂层种类 Grade	特性 Application	颜色 Colour		硬度 Hardness	厚度 Thickness	摩擦系数 Friction versus	应用温度 Application temp
				HV	μm		$^{\circ}\text{C}$
TiN	普通用途涂层。适用于低速铣削、铰削钢材。 Low speed milling and reamering of steels.	金 Gold		2400	1-4	0.5	700
TiCN	高韧性涂层。适用于铣削、攻丝和滚齿。 With high toughness.Milling,tapping and hobbing	蓝-灰 Purple-grey		3700	1-4	0.35	350
CrN	适用于航空材料加工。 Milling of aerial material.	银 Silvery		1500	1-3	0.4	750
TiAlN单层	高抗热，高性能。适用于淬硬钢、合金钢、不锈钢的高速切削及干切削。 Heat-resisting.High speed and dry milling and drilling of stainless and heat-resistant steel.	紫-黑 Purple-black		3500	1-4	0.5	850
TiNIN多层	高抗热，高性能。适用于淬硬钢、合金钢、不锈钢的高速切削及干切削、重载切削。 Heat-resisting.High speed and dry milling and drilling of stainless and heat-resistant steel.	紫-黑 Purple-black		2800	1-3	0.6	750
AlTiN	特殊涂层，高铝元素含量，极高抗热性及高硬度，适用于高速加工 High speed milling of steel.	黑 Black		3800	1-3	0.7	850



自贡硬质合金有限责任公司
成都格润特新材料有限公司
ZIGONG CEMENTED CARBIDE CORP., LTD.
CHENGDU GERUNTE HIGH-TECH MATERIAL CO., LTD.



® 铰削刀具 Reamers





● 铰 刀 Reamers

直径范围 Diameter mm	直径公差等级 Dia tolerance class	总长 Length mm	供货标准 Technical of the delivery conditions
Ø3 ~ Ø30	H7/H8/H9 $\Delta_{\min}=0.005$	< 300	DIN2172-1/2-97
被加工材料 To-be machined material	钢、不锈钢、高温合金、钛合金、铸铁、铝合金 Steels, Stainless steels, Heat-resistant steels, Titanium alloys, Cast iron, Aluminium alloys		



● 枪铰刀 Gun reamers

直径范围 Diameter mm	直径公差等级 Dia tolerance class	总长 Length mm	供货标准 Technical of the delivery conditions
Ø6 ~ Ø15	$\Delta_{\min}=0.005$	< 300	ZGST*
被加工材料 To-be machined material	铸铁、铝合金 Cast iron, Aluminium alloys		
Properties	Internal coolant supply		



● 铣铰刀 Reamers with milling

直径范围 Diameter mm	直径公差等级 Dia tolerance class	总长 Length mm	供货标准 Technical of the delivery conditions
Ø5 ~ Ø30	H7/H8/H9 $\Delta_{\min}=0.005$	≤150	ZGST*
被加工材料 To-be machined material	不锈钢、高温合金、钛合金 Stainless steels, Heat-resistant steels, Titanium alloys,		



自贡硬质合金有限责任公司
成都格润特新材料有限公司
ZIGONG CEMENTED CARBIDE CORP., LTD.
CHENGDU GERUNTE HIGH-TECH MATERIAL CO., LTD.



模具铣刀刀片

Indexable inserts for die milling cutter



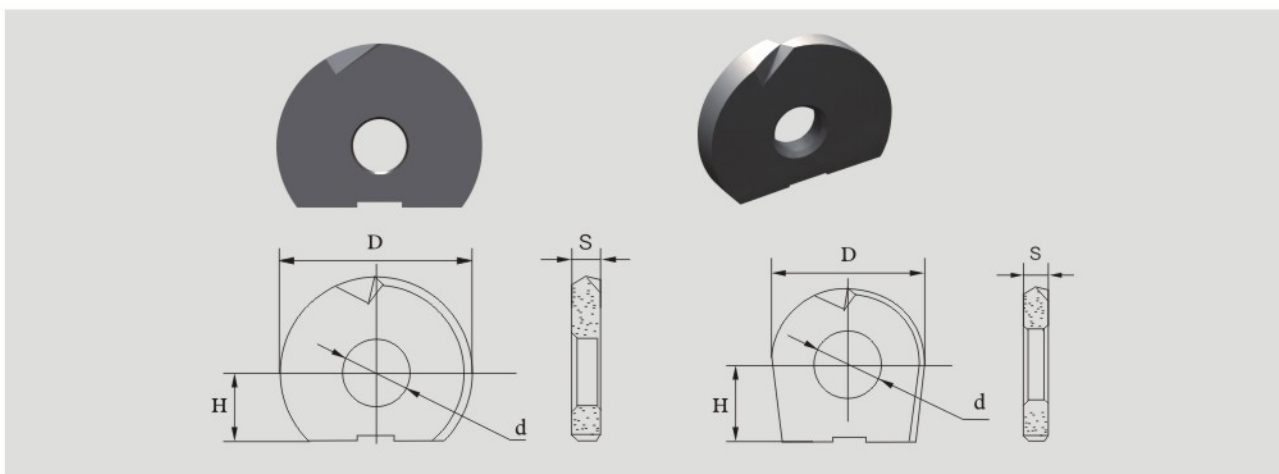

型号 Type	尺寸 Dimensions mm			
	D	S	d	H
SRC1002A	10	2.5	4	5
SRC1202A	12	2.5	5	6
SRC1603A	16	3	5	6
SRC2003A	20	3	5	6
SRC2503A	25	4	5	7

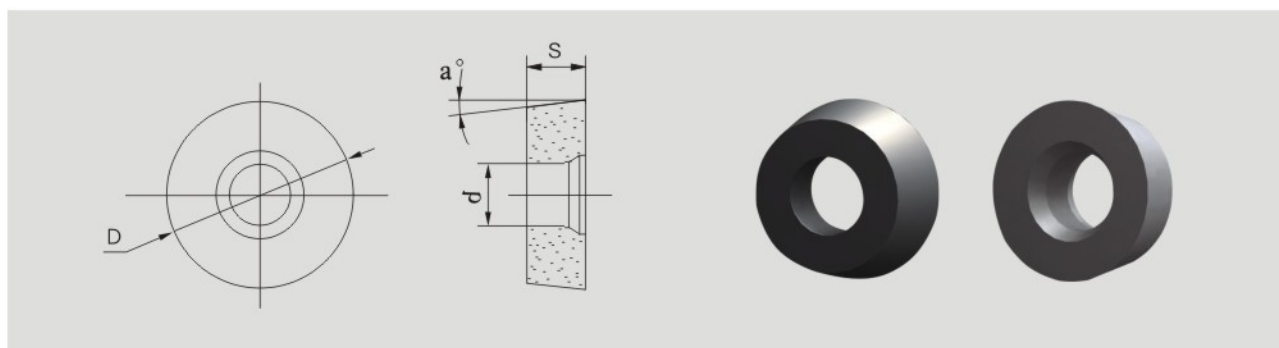

型号 Type	尺寸 Dimensions mm			
	D	S	d	a°
RCMW060200	6	2.38	2.8	7°
RCMW080300	8	3.18	3.4	7°
RCCW10T300	10	3.97	4.4	7°
RPCW100300	10	3.18	4.4	11°
RPCW120400	12	4.76	4.4	11°
RPCW160500	16	5.56	5.5	11°
RCGT200600	20	6.35	6.65	7°



自贡硬质合金有限责任公司
成都格润特新材料有限公司
ZIGONG CEMENTED CARBIDE CORP., LTD.
CHENGDU GERUNTE HIGH-TECH MATERIAL CO., LTD.



钻削刀具 Drills



钻削刀具 Drills



- ① 麻花钻 Twist-drills
- ② 深孔钻 Gun drill

直径范围 Diameter mm	刃数 Flutes	直径公差等级 Dia tolerance class	总长 Length mm	供货标准 Technical of the delivery conditions
① $\varnothing 3 \sim \varnothing 20$ ② $\varnothing 6 \sim \varnothing 20$	2	h8	① < 150 ② < 300	DIN6540-1/2-93
被加工材料 To-be machined material	钢、不锈钢、高温合金、钛合金、铸铁、铝合金 Steels, Stainless steels, Heat-resistant steels, Titanium alloys, Cast iron, Aluminium alloys			



- 中心钻 Center drills
- 定心钻 NC-spotting drills

直径范围 Diameter mm	总长 Length mm	供货标准 Technical of the delivery conditions
$\varnothing 4 \sim \varnothing 20$	< 150	DIN6529-92 ZGST*
被加工材料 To-be machined material	不锈钢、耐高温钢 Stainless steels-resistant steels,	



- 扩孔钻 Core drill

直径范围 Diameter mm	刃数 Flutes	直径公差等级 Dia tolerance class	总长 Length mm	供货标准 Technical of the delivery conditions
$\varnothing 3 \sim \varnothing 20$	3	h8	< 300	DIN6540-1/2-93
被加工材料 To-be machined material	钢、不锈钢、高温合金、钛合金、铸铁、铝合金 Steels, Stainless steels, Heat-resistant steels, Titanium alloys, Cast iron, Aluminium alloys			



- 直槽钻 Solid carbide drills with straight flute

直径范围 Diameter mm	刃数 Flutes	直径公差等级 Dia tolerance class	总长 Length mm	供货标准 Technical of the delivery conditions
$\varnothing 5 \sim \varnothing 20$	2	(刃)h9/e8(柄)	< 150	DIN6529-92 ZGST*
被加工材料 To-be machined material	钢、高温合金、钛合金、铝合金 Steels, Heat-resistant steels, Titanium alloys, Aluminium alloys			